



C. Examination: When setting the switch on the bottom of the lamp holder (2) (see the figure below) to the left side, the lamp in the holder shall be lighted, snowflake shall fall down and music shall start at the same time. If it fails to perform such functions, it is necessary to check if the joints ①, ②, ③, ④, ⑤ and ⑥ are well connected or ask experienced engineer for help until it can perform the abovementioned functions. You can also turn the switch to the right side to close the music.



5. Decorate and enjoy

As shown in the figure below, fix the wreath + bowknot (13) to the upper side of the lamp post to make the street lamp beautiful. If the street lamp is to be installed outside, to avoid wind and rain, there is no need to install this decoration. That's all of the installation steps. Now you can enjoy this type of snowing and musical street lamp visually and acoustically.

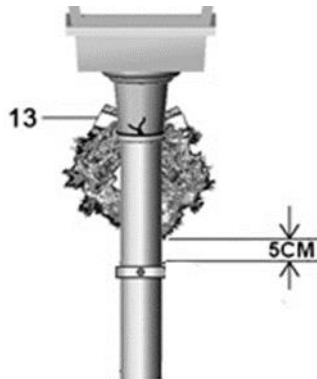

Snowing Christmas Lamp Post



FUSION PRODUCTS LTD.

Model # 17375

Table of Contents

Schematic Diagram	1
Component List	2
Assembling Steps.....	3-6

Overview

This product is designed to the highest technical specifications and standards. It will supply years of maintenance free use. Please read these instructions thoroughly prior to installation, then store in a safe place for future reference. If at any time you are unclear about this product, or require further assistance please do not hesitate to contact our trained professionals operating the customer support line at 1-877-615-1378 Monday to Friday between the hours 8:30 AM to 5:00 PM Eastern Standard Time or email sales@fusionproducts.ca

Getting Started

Please do not throw away any packing material until all parts are verified as present.

1-YEAR LIMITED PRODUCT WARRANTY

This product is covered under a one year limited warranty. Fusion Products Ltd. warrants to the original purchaser that this product is free from defects in materials and workmanship for the period of one year warranty from date of purchase.

**For Technical Support and/or Warranty Inquiries
please contact: Fusion Products**

Monday to Friday

8:30-5:00PM EST

2905 Argentia Road, Unit 2

Mississauga, Ontario L5N 8G6

Tel: 1-877-615-1378 Tel: (905) 812-9470

Fax: (905) 812-3256

Email: sales@fusionproducts.ca

B. Take out the lamp holder (2) and put on the lamp top (1);

C. Draw out the joint ⑥ and the power line (14), connect the joints ⑤ and ⑥, put the combined joints and their wires into lamp post (3). **Note:** At this time, it will be better to ask another person to hold the lamp holder (2) in case of dropping it down!

D. Rotate the lamp holder (2) to fasten it on the lamp post (3). **Note:** The screw thread shall be tightened as far as possible. Meanwhile the direction of the lamp holder (2) shall be slightly adjusted to make it match the direction of the lamp bases (9) and (10).

4. Positioning, power-on, waterproof and examination

A. Positioning: Place carefully the assembled street lamp at the set position. **Note: (1)** If the street lamp is to be installed outdoor, please fix the lamp base with ground nails in case that high wind blows it down; **(2)** The street lamp shall be placed at a location without man-made interference in case of damages. **(3)** If the street lamp is to be installed indoor and easy to be influenced by man-made interference or is to be installed outdoor and ground nails cannot be used, please be sure to use additional base (7) to keep it secure.

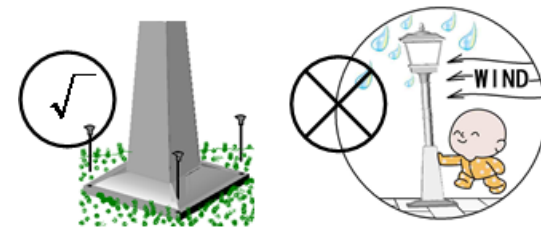

B. Power on: Tightly connect the two joints ① and ④ of the adaptor (4) and power wire (6). If the power wire isn't long enough, it is able to add the extended wire (5) between them, and then connect the adaptor (4) with the main power source.

C. Waterproof: (1) The adaptor itself is not waterproof, so make sure that the connection point between the adaptor and the main power source is indoor or at a place free of rainwater or snow in case of electric leakage or electric shock! **(2)** The lamp holder (2) shall be kept vertical to ensure waterproof effect; **(3)** If the street lamp is used outside, all joints of ①and ②, ③and④, ⑤and⑥ must be tightened in case of water seepage and electric leakage!

2. Install lamp post

Screw the 2 lamp posts (3), lamp post joints (12) and square lamp base (10) together according to the sequence shown in the figure below. **Note:** Every screw thread must be tightened; otherwise, the lamp posts may lean or get loose!

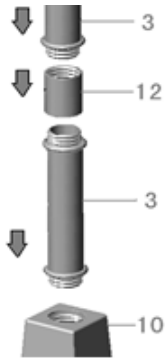

3. Install lamp holder

A. Thread the power wire (6) and its joint (5) through the lamp base and lamp post (the lamp base and lamp post can be laid down or put upside down for convenience. After drawing out the joint (5), place it correctly for later use);

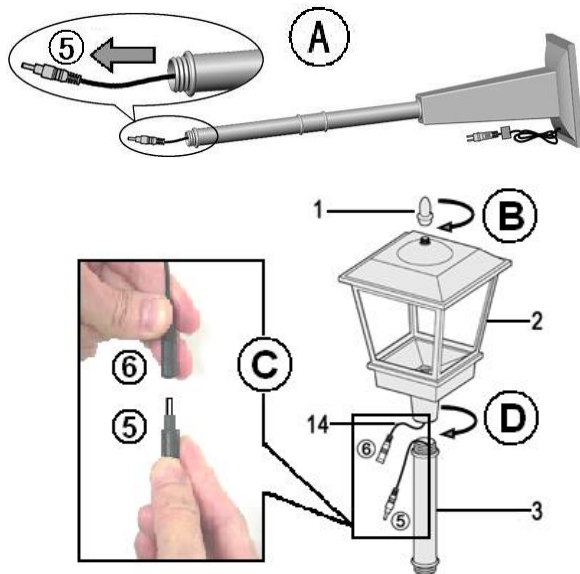

Caution

- This product (especially the lamp holder) is fragile, so please do not exert too much strength or drop it during the assembly and use!
- This product is waterproof; but it is necessary to keep the lamp in the vertical direction to ensure the waterproof effect.
- Please assemble it in strict accordance with the steps and requirements specified in the instruction to ensure safety, reliability and speed during the installation.

I. Schematic diagram

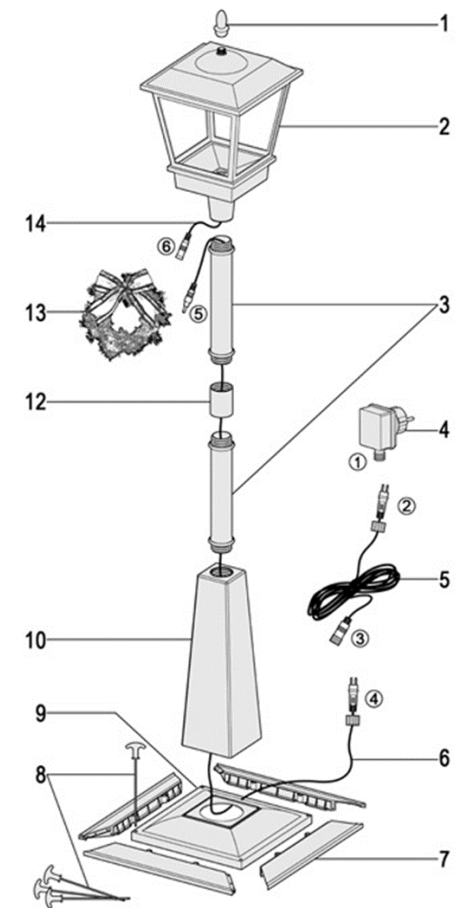

II. Component list

No.	Name	Number
1	Lamp top	1
2	Lamp holder	1
3	Lamp post (43cm)	2
4	Adapter (12V AC 500mA)	1
5	Extended wire (3.5m)	1
6	Power wire (3.5m) (inside lamp post: 1.5m, outside: 2m)	1
7	Additional base	1 set (4)
8	Ground nail	4
9	Lamp base	1
10	Square base	1
12	Lamp post joint	1
13	Wreath+ bowknot	1 set
14	Power wire of lamp holder	1
15	Screw	12+1
Note: ①②③④⑤⑥ are all wire joints.		

III. Assembling steps

Please assemble the product from the bottom to the up, following the main steps below:

1. Install lamp base

A. Assemble lamp base (9) and square base (10) with 4 large screws:

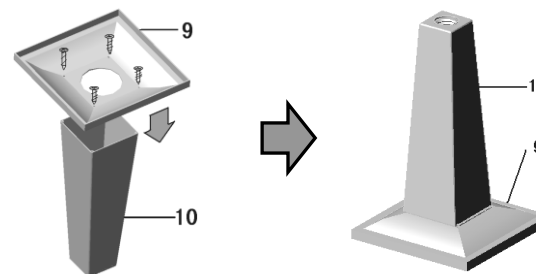

B. Assemble 4 pieces of additional base (7) into a whole, and then use 8 small screws to assemble the whole additional base (7) with the lamp base (9).

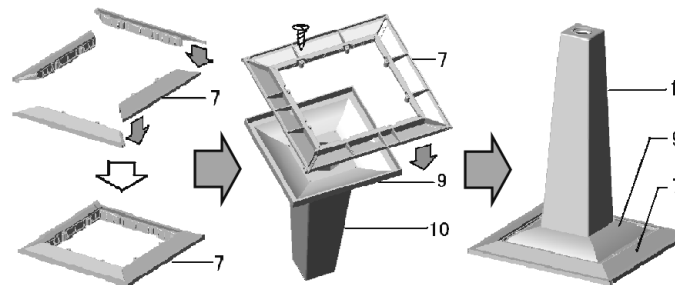

Note: The additional base (7) is especially designed to fasten the street lamp more securely. If the street lamp is installed on a flat ground and there is no external force (such as high wind or man-made interference) to bring it down, or if the street lamp is used outdoor and it can be fixed on the ground by fastening ground nails, there is no need to install additional base (7). In other words, users can decide whether to install the additional base (7) according to the actual condition.